

C 型軌 扁電纜 供電系統

C Track & Flat Cable Power Supply System



- 一、設計 (P1)
- 二、PVC移動式扁電纜線 (P4)
- 三、C30軌道零件圖 (P5)
- 四、C40軌道零件圖 (P7)
- 五、鋁軌道零件圖 (P8) *將停產*
- 六、安裝示意圖 (P9)

應用範圍：

- 吊車橫行供電系統
- 自動電鍍設備
- 汙水處理廠供電系統
- 石材機械、移動式控制系統
- 一般重工機械吊車移動式供電

一、設計 / Design

C型軌固定架 (可使用C型軌截短代替)
Support arm (use short c-track)

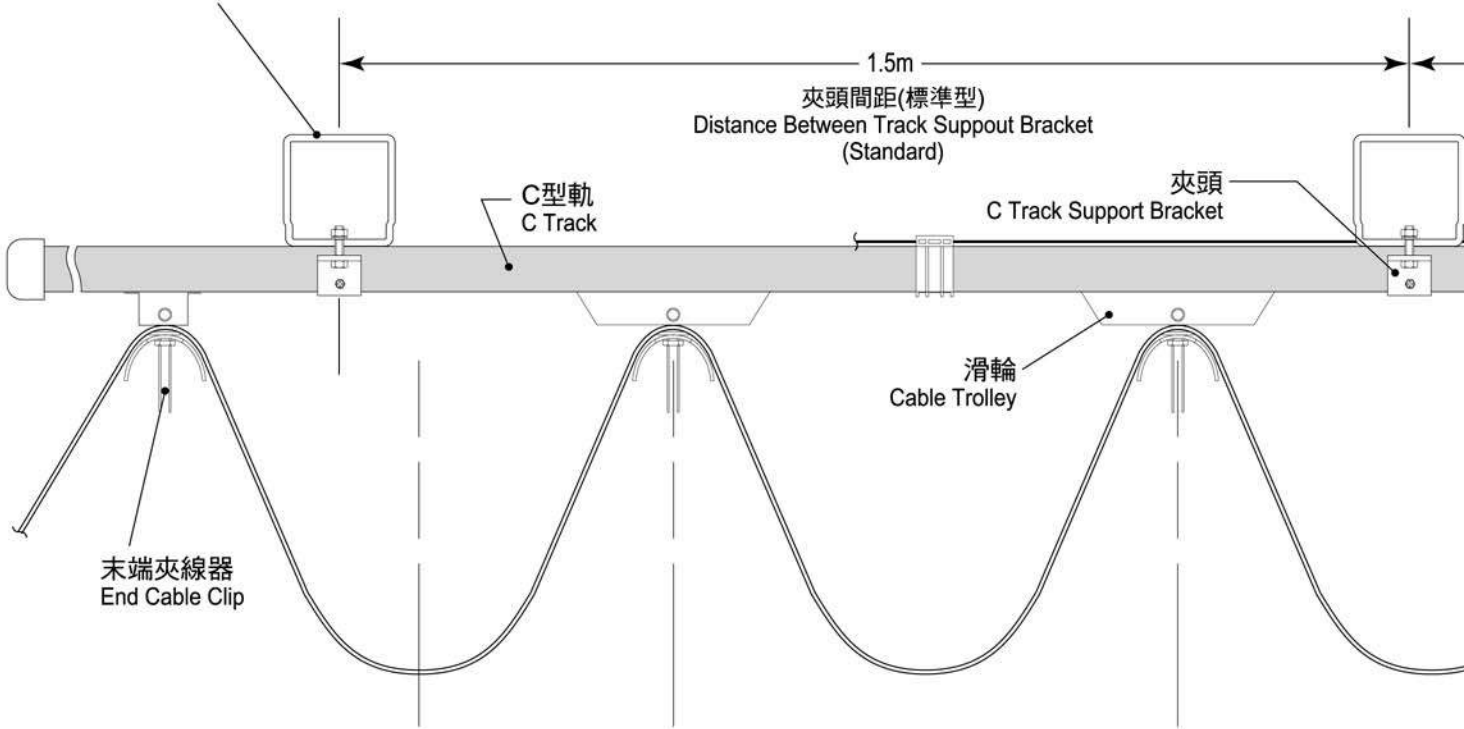

一、結構數據

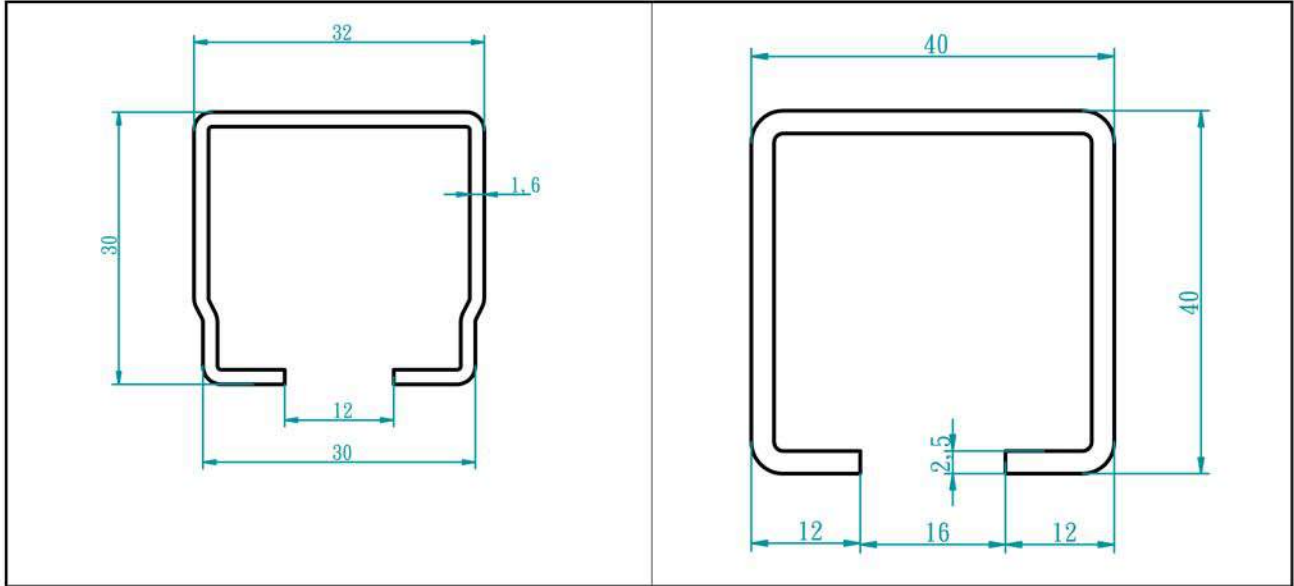

C30軌道斷面圖

C40軌道斷面圖

產品編號	材質	長度 (mm)	厚度S (mm)	物理性質			單位重量 (kg/m)
				Ix (cm ⁴)	Wx (cm ³)	e (mm)	
KY-BC3030	鍍鋅鋼板	3000	1.6±0.1	1.97	1.23	16	1.15±0.1
KY-BC4030	鍍鋅鋼板	3000	2.5±0.1	6.74	3.08	21.6	2.43±0.1

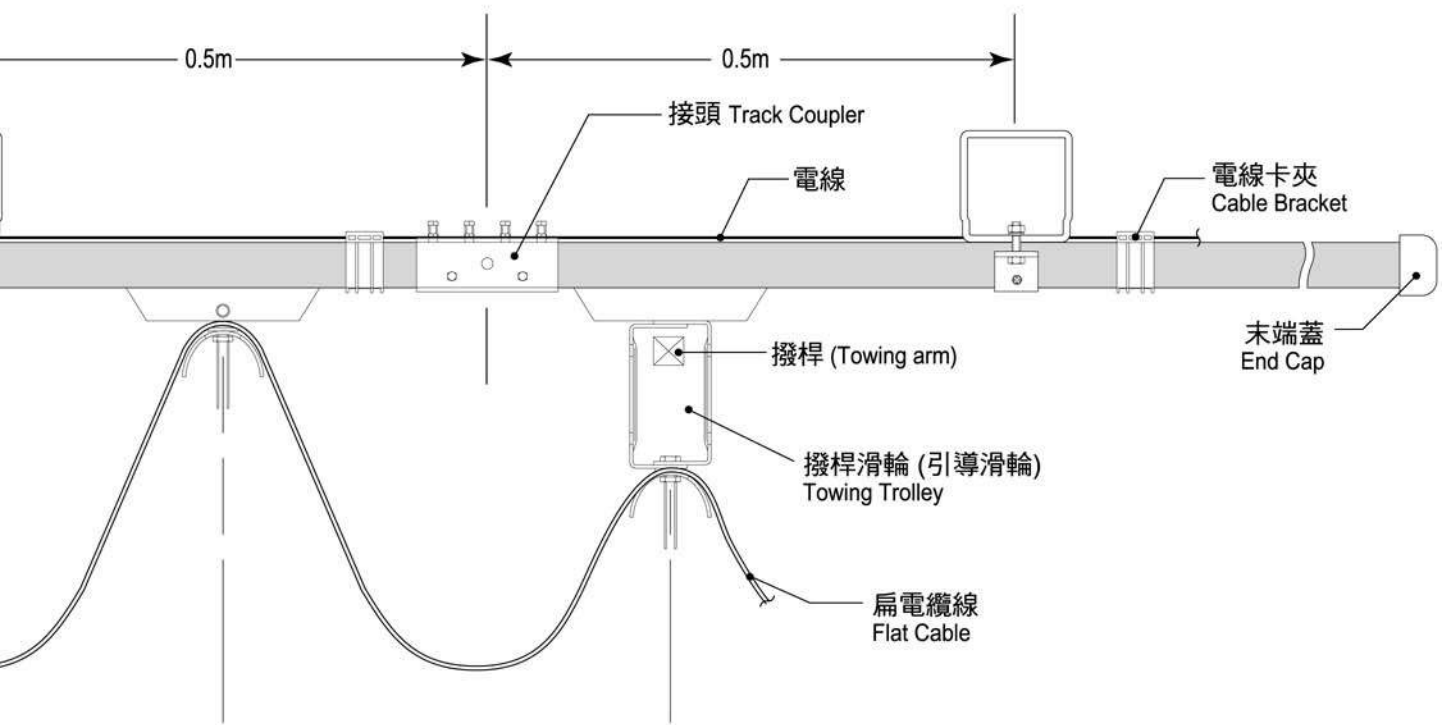

二、規劃

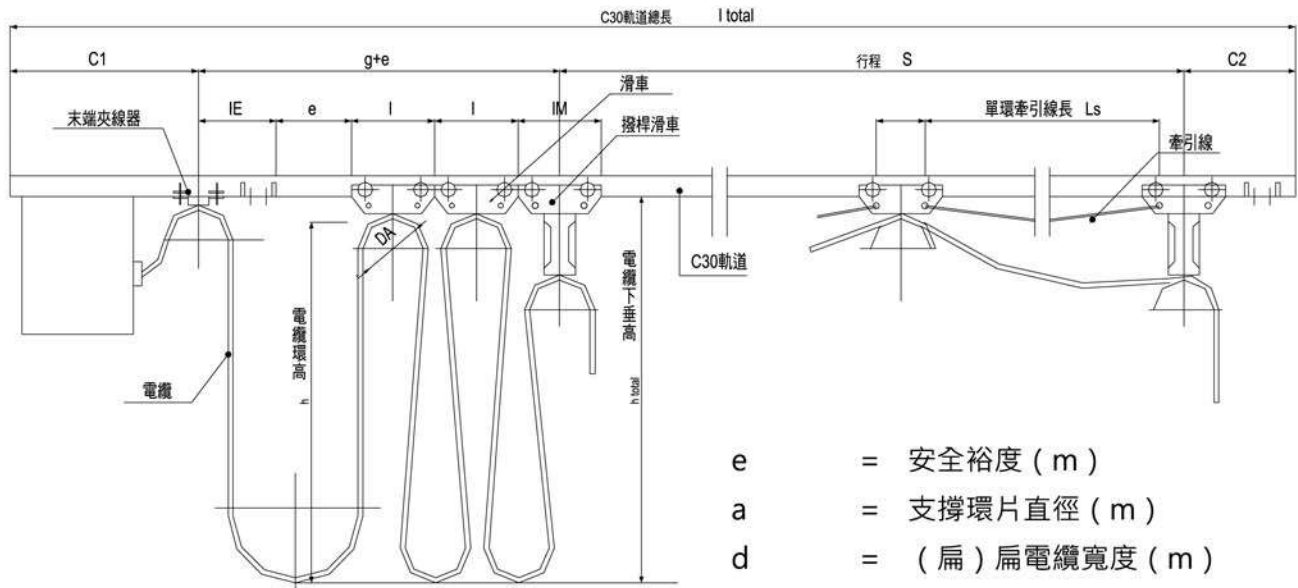

- I_{total} = C30或C40軌道總長 (m)
- S = L 行程 (m)
- h = 電纜環高 (m)
- h_{total} = 電纜下垂高 (m)
- n = 電纜的環數 (環)
- g = 滑車及配件需求長 (m)
- l = 滑車長 (m)

- e = 安全裕度 (m)
- a = 支撐環片直徑 (m)
- d = (扁) 扁電纜寬度 (m)
- f = (扁) 扁電纜長度係數
- L_{total} = (扁) 扁電纜總長度 (m)
- L_{loop} = (扁) 扁電纜總單環長度 (m)
- L_s = 單環牽引線長 (m)

$$n = f \times \frac{s+g}{2h} \quad h = f \times \frac{s+g}{2n}$$

$$f = 1.1 \text{ (滑行速度 } 50 \text{ m/min)}$$

三、C30、C40軌道設計資料

C30軌道 已知 ---

P=4 單組滑車承載重量 (Kg)

lw=85 滑車長 (mm)

Z=11 滑車數量 (組) 所以滑車數總長 $L=Z \times lw / 1000 = 0.93$ (M)

所以可從下表求得 ---

La=1.3 C30夾頭支撐點間距 (M)

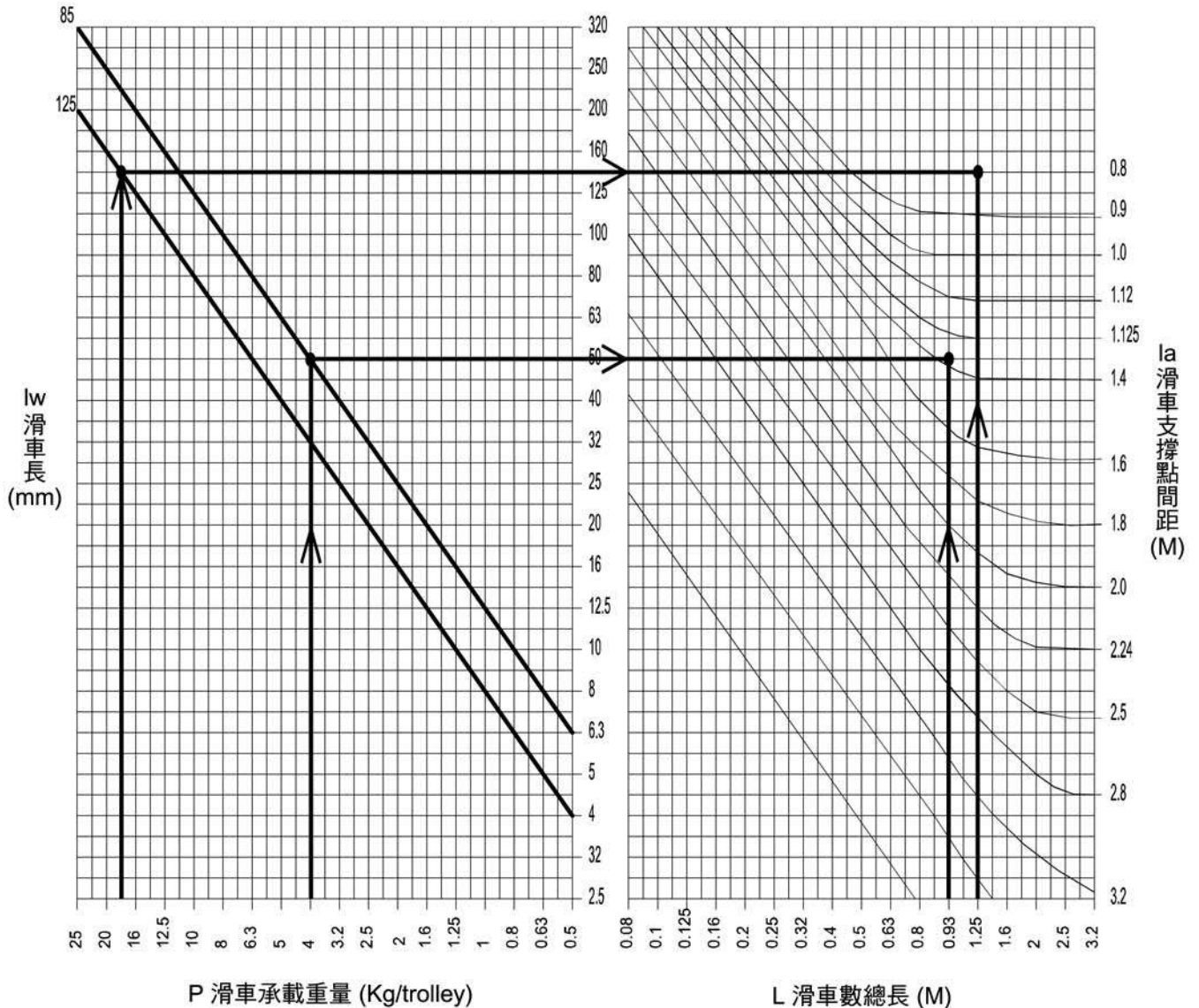

C40軌道 已知 ---

P=18 單組滑車承載重量 (Kg)

lw=125 滑車長 (mm)

Z=10 滑車數量 (組) 所以滑車數總長 $L=Z \times lw / 1000 = 1.25$

所以可從下表求得 ---

La=0.8 C40夾頭支撐點間距 (M)

$= 10 \times 125 / 1000 = 1.25$ (M)

二、PVC移動性扁電纜線 / PVC Flat Cable



DESCRIPTION :

- Bare Stranded copper conductor.
- PVC insulation, Rated temp 60°C, 80°C or 105°C available.
- PVC jacket, Acid bafe resistance available or UL Type.

產品說明：

- 導體：裸軟銅線絞合。
- 蕊線：PVC材質，耐溫60°C、80°C或指定105°C。
- 外披：PVC披覆，亦可指定耐酸鹼材質或UL規範。

導體		蕊線數	絕緣厚度	蕊線外徑	完成外徑	導體電阻	試驗電壓	絕緣電阻	重量/百米
Conductor		No. of Core	Insulation thickness	Insulation Diameter	Overall Diameter	Characteristica			Weight
斷面積 MM	線數 / 線徑 NO. / mm					20°C (Ω/KM)	V/MIN	M/KM	
0.75	30 / 0.18	24	0.6	2.3	8.3 x 40.3	25.8	1500	50	60.50
0.75	30 / 0.18	36	0.6	2.3	11 x 51	25.8	1500	50	76.00
1.25	50 / 0.18	3	0.8	3.0	5.0 x 11.2	16	1500	50	10.10
1.25	50 / 0.18	4	0.8	3.0	5.8 x 15.7	16	1500	50	14.74
1.25	50 / 0.18	5	0.8	3.0	6.1 x 18.8	16	1500	50	20.10
1.25	50 / 0.18	8	0.8	3.0	5.0 x 28.7	16	1500	50	31.00
1.25	50 / 0.18	10	0.8	3.0	5.1 x 34.6	16	1500	50	35.00
1.25	50 / 0.18	13	0.8	3.0	5.2 x 43	16	1500	50	40.00
2.0	37 / 0.26	3	0.8	3.2	5.0 x 11.4	10.2	1500	50	11.85
2.0	37 / 0.26	4	0.8	3.2	6.8 x 18.6	10.2	1500	50	21.00
2.0	37 / 0.26	8	0.8	3.2	6.0 x 29.5	10.2	1500	50	36.70
3.5	140 / 0.18	3	0.8	4.2	6.3 x 16.2	5.54	1500	50	23.00
3.5	140 / 0.18	4	0.8	4.2	7.5 x 19.5	5.54	1500	40	31.00
3.5	140 / 0.18	8	0.8	4.2	6.8 x 39	5.54	1500	40	57.00
5.5	217 / 0.18	3	1.0	5.2	7.5 x 20	3.56	1500	40	32.00
5.5	217 / 0.18	4	1.0	5.2	8.0 x 23	3.56	1500	40	39.70
8	315 / 0.18	3	1.0	6.2	9.0 x 21.6	2.54	1500	40	44.00
8	315 / 0.18	4	1.0	6.2	10 x 30	2.54	1500	40	59.00
14	550 / 0.18	3	1.0	7.6	12 x 28.8	1.43	1500	40	72.00
14	550 / 0.18	4	1.0	7.6	10.6 x 33	1.46	1500	40	96.00
22	855 / 0.18	3	1.2	10.0	15 x 35	0.919	1500	40	100.00
22	855 / 0.18	4	1.2	10.2	13 x 47	0.919	1500	40	145.00
38	1480 / 0.18	3	1.2	12.5	17.8 x 42.5	0.75	1500	40	222.00
38	1480 / 0.18	4	1.2	12.5	20 x 53	0.75	1500	40	255.00

三、C30軌道零件圖 / C30 Track Design

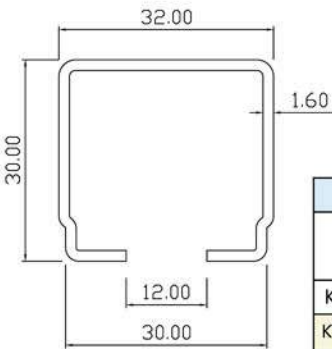
KY-BC3030	
C30 軌道	
C30 TRACK 3M	
KG/PC	3.4Kg / 3M
KY-BCS3030 白鐵 SUS304	



KY-BCS3030 C30軌道 白鐵 SUS304

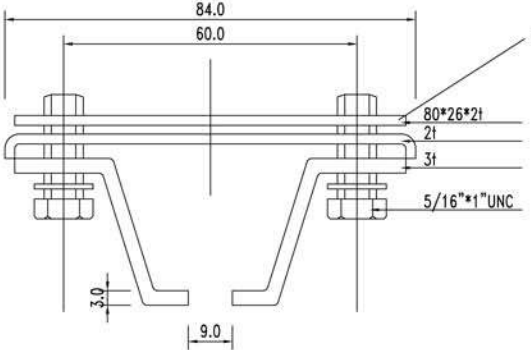

KY-BC3100	KG / PC
C30 夾頭	0.21 Kg
C30 Track Support Bracket	
KY-BCS3100 白鐵	0.20 Kg



KY-BC3103	KG / PC
C 夾片	0.17 Kg
Track Clip	

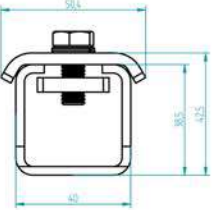

KY-BC3102	KG / PC
C30 支架結合座	0.44 Kg
Support arm	

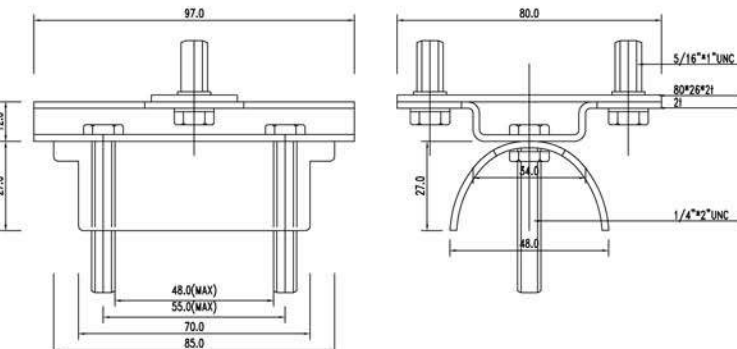



KY-BC3200	
C30 末端夾線器	
C30 End Cable Clip	
KG/PC	0.30 Kg
KY-BCS3200 白鐵	
End Cable Clip (SUS)	
KG/PC	0.29 Kg

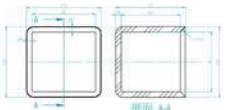

KY-BC3201	KG / PC
C30 末端蓋	0.01 Kg
C30 End Cap	

KY-BC4201	KG / PC
C40 末端蓋	0.01Kg
C40 End Cap	



KY-BC3202	KG / PC
C30 電線卡夾	0.01
C30 Cable bracket	



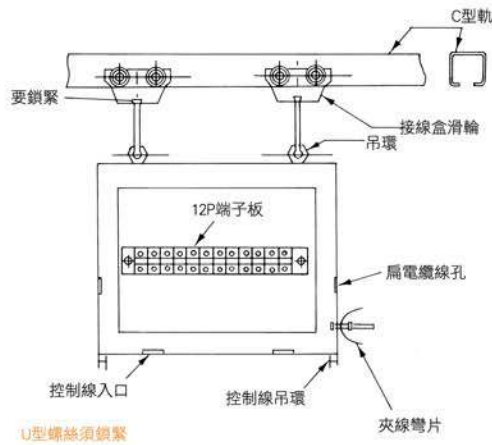
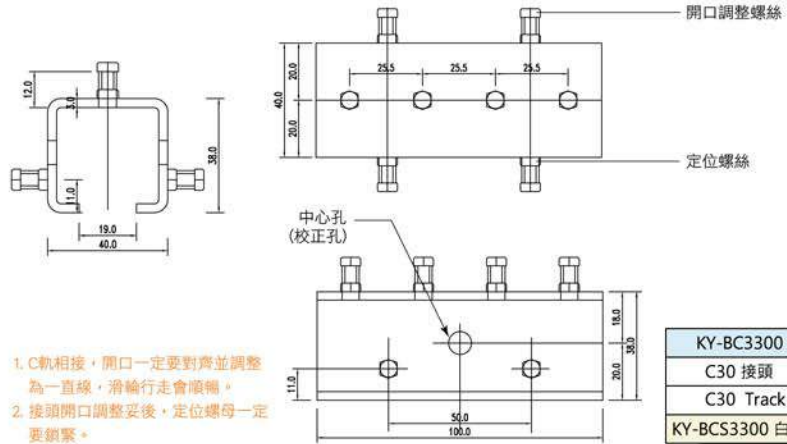
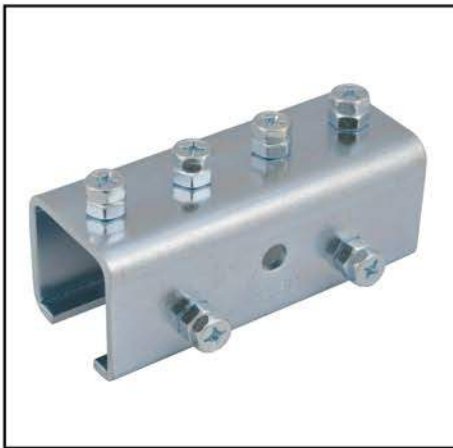

KY-BC3412	KG / PC
C30 接線盒(黑色),12pin	2.67 Kg
C30 Connect box,12pin	
KY-BC3412A	KG / PC
C接線盒(快速接頭),16pin	1.58 Kg
C connect trolley (new),16pin	

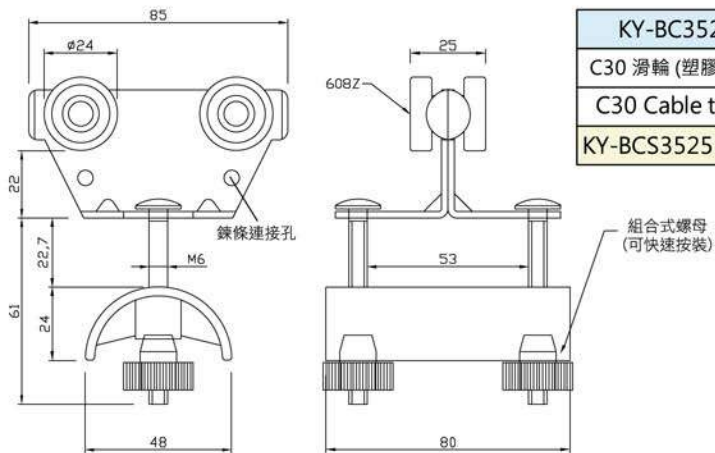

KY-BC3525	KG / PC
C30 滑輪 (塑膠彎片)	0.28 Kg
C30 Cable trolley (Plastic)	
KY-BCS3525 白鐵	0.33 Kg

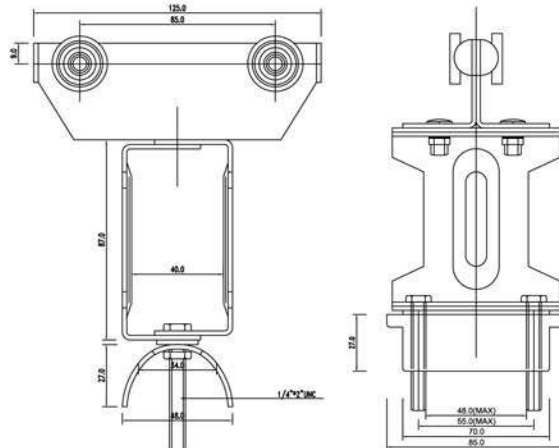

KY-BC3625	KG / PC
C30 撥桿滑輪	0.78 Kg
C30 Towing Trolley	
KY-BCS3625 白鐵	0.79 Kg

四、C40軌道零件圖 / C40 Track Design

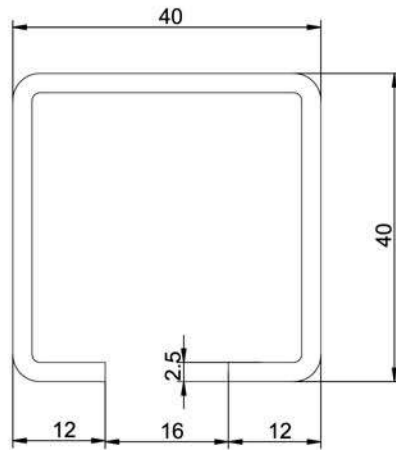

KY-BC4030	KG / PC
C40 軌道	支 / 3M
C40 Track	7.30Kg
KY-BCS4030 白鐵 SUS304	
C40 Track SUS304	7.28Kg

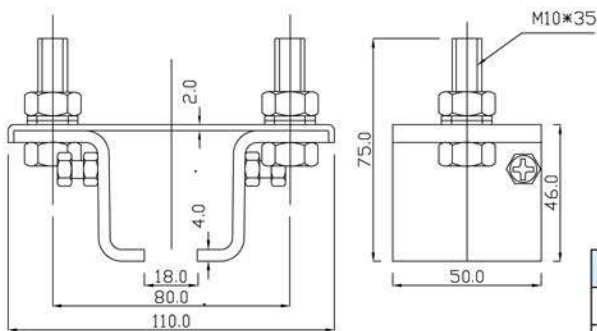

KY-BC4100	KG / PC
C40 夾頭	0.40Kg
C40 Track Support Bracket	
KY-BCS4100 白鐵	0.41Kg

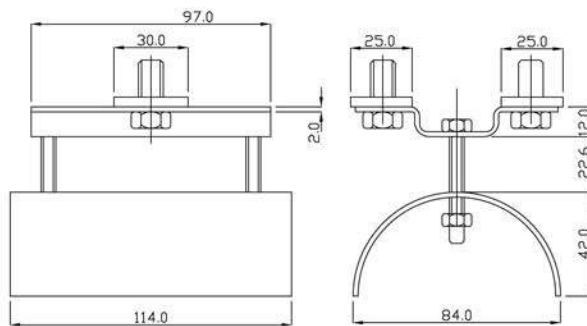

KY-BC4200	KG / PC
C40 末端夾線器	0.46Kg
C40 End Cable Clip	
KY-BCS4200 白鐵	0.46Kg

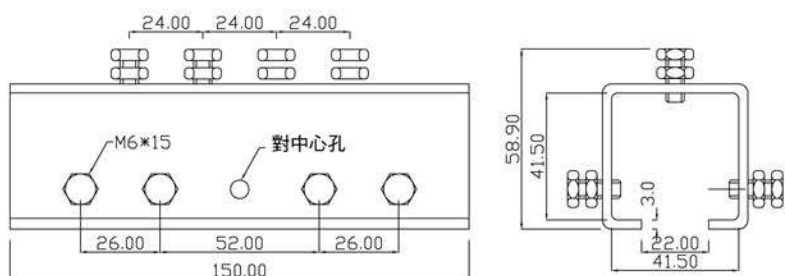

KY-BC4300	KG / PC
C40 接頭	0.59Kg
C40 Track Coupler	
KY-BCS4300 白鐵	

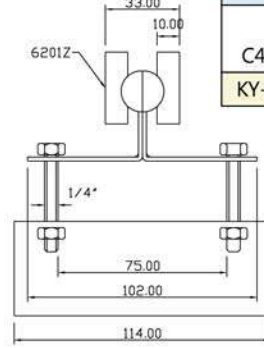
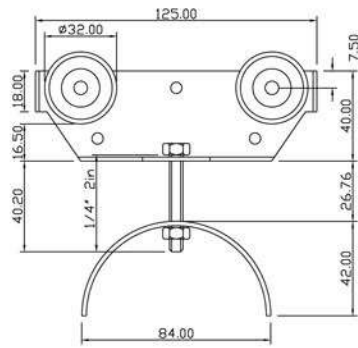

KY-BC4525	KG / PC
C40 滑輪 C40 Cable trolley	0.70Kg
KY-BCS4525 白鐵	0.70Kg

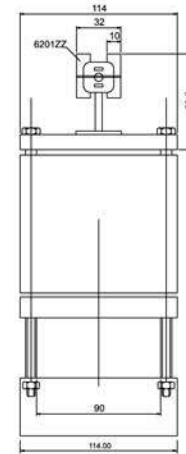
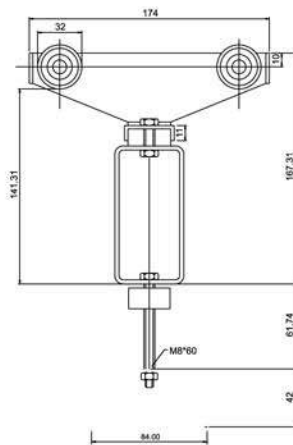

KY-BCS4625 白鐵 1.17Kg

KY-BC4625	KG / PC
C40 撥桿滑輪 C40 Towing Trolley	1.69Kg

五、鋁軌道零件圖 / Aluminum Track Photog * 將停產 *



KY-BD3030	KG / PC
鋁軌道 Al. Track	支/3M 1.79Kg

KY-BD3300	KG / PC
鋁軌接頭 Coupler	0.18Kg



KY-BD3100	KG / PC
鋁軌夾頭 Support Bracket	0.13Kg

KY-BD4525	KG / PC
鋁軌鐵滑輪 (塑膠彎片) Cable trolley (Plastic)	0.27Kg



六、安裝示意圖 / Installation Demonstration

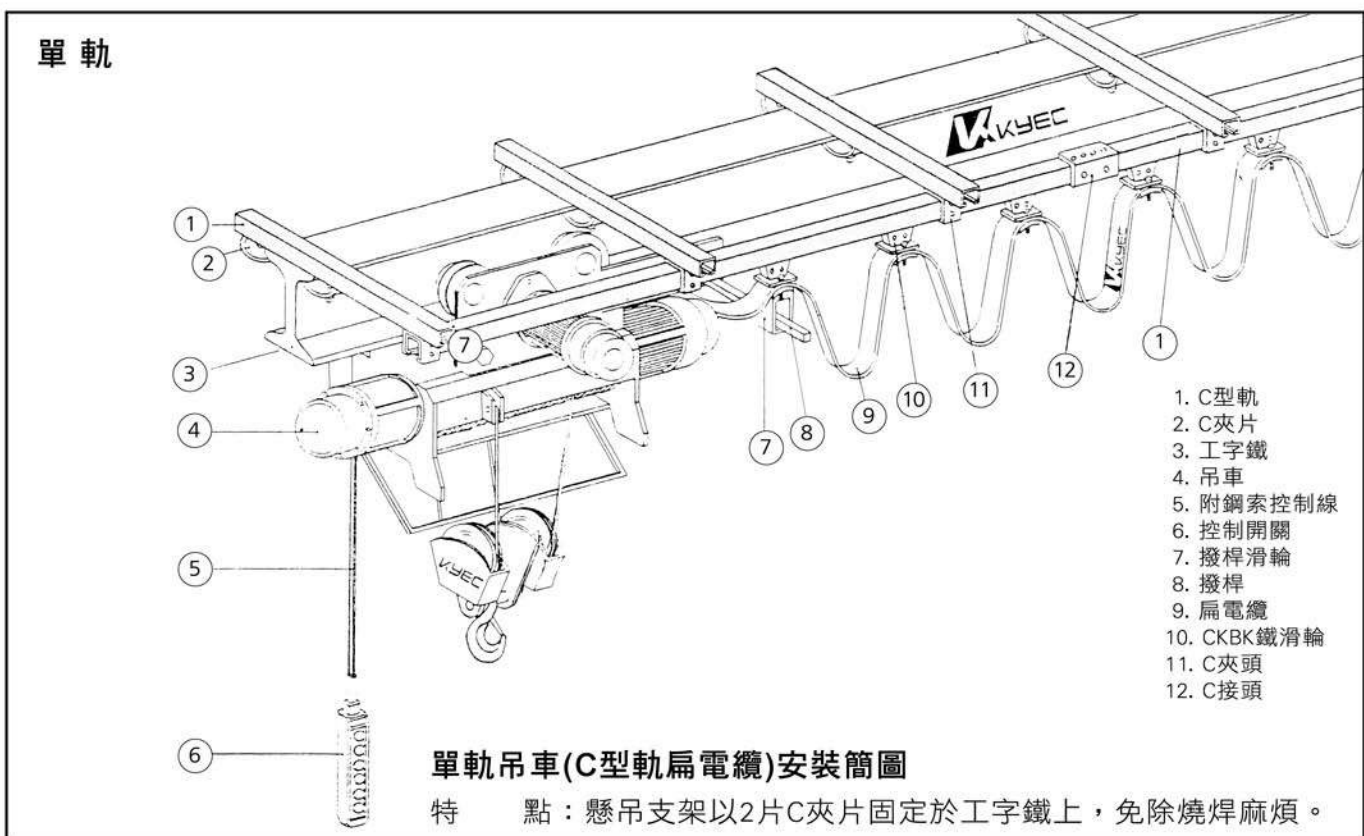
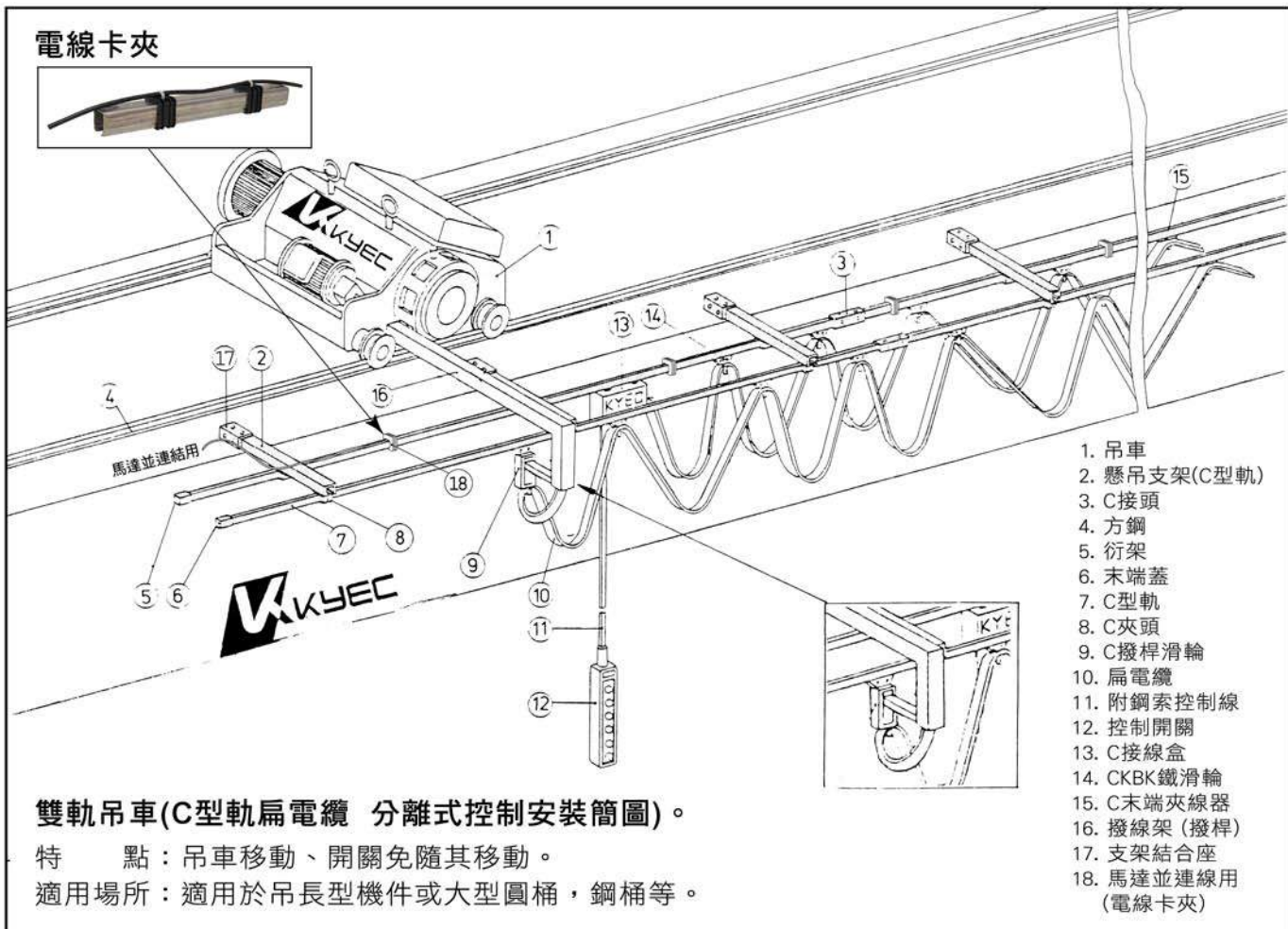

鋼索式滑車



KY-OWP206	
專利滑輪	KG / PC
Cable trolley	0.07Kg
KY-OWS107	
鋼索鐵滑輪	KG / PC
Cable trolley (Steel)	0.15Kg

KY-OWS005	
鋼索鐵滑輪夾扁電纜	KG / PC
Trolley	0.40Kg



工字鐵吊輪



KY-OIW075100	
W吊輪 75W-100W	KG / PC
W Type Trolley (S)	0.37Kg
I steel 75~100mm	

KY-OIW125150	
W吊輪 125W-150W	KG / PC
W Type Trolley (L)	0.40Kg
I steel 125~150mm	



KY-OIU075150	
U型吊輪(直)正軸承 75W-150W	KG / PC
Cable Trolley 75W~150W	0.49Kg

KY-OIU075125C	
U型吊輪(彎)正軸承 75W-125W	KG / PC
Cable Holder 75W-125W	0.58Kg

KY-OIU150250C	
U型吊輪(彎)正軸承 150W-225W	KG / PC
Cable Holder 150W-225W	0.64Kg

KY-OIU300C	
U型吊輪(彎)正軸承 300W	KG / PC
Cable Holder 300W	0.68Kg



訂製品



KY-OIH250W	
H滑車 250W	KG / PC
H Trolley 6"	4.58Kg

另有：75W、100W、125W、150W、200W...等各類規格，歡迎來電洽詢！

Special Goods	
H滑車 進口型式	KG / PC
H Trolley (Import)	依規格



七、彎曲方管 / Diamond Track (For Curve)

扁電纜搭配方管之彎曲式電源供電應用系統



KY-BGNL38*2 扁電纜抗拉帶 38mmx2mm 100M/捲/6Kg

★增加一條抗拉帶可降低電纜斷裂的機率。

產品應用：

彎曲式電源供應系統
防爆式電源供應系統
跨距式電源供應系統
移動式電源供應系統
重型機械供電系統
自動電鍍設備
汙水處理工廠

八、方管軌道 / Diamond Track 3 meter

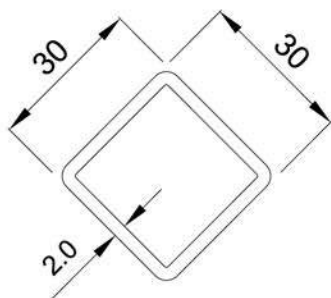

長度：3M/PC

方管以菱形軌方式安裝

KY-OISP300	
方管軌道 30x30x2.0	KG/PC
Diamond Track 30x30x2.0 3 meter	5.65 Kg

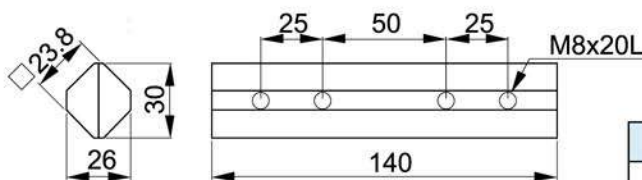

連接螺絲：

六角形螺絲 M8x20L

KY-OISP308	
方管接頭	KG /PC
Diamond Track Coupler	0.37Kg

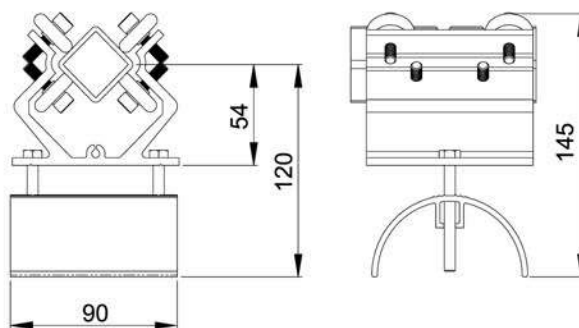

內六角平圓頭螺絲 M6x35

六角形螺絲 M6x15

六角形螺絲 M6x50

KY-OISP306	
方管滑輪 30x30	KG/PC
Diamond Track Trolley 30x30	0.7 Kg

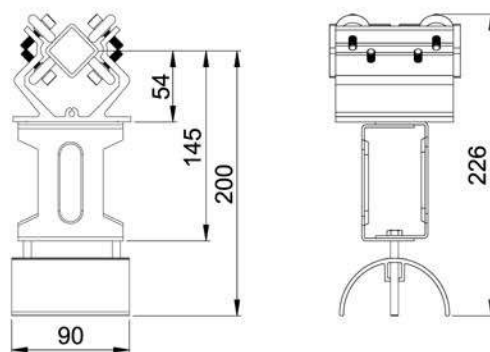

內六角平圓頭螺絲 M6x35

六角形螺絲 M6x50

KY-OISP326	
方管牽引滑輪 30x30	KG/PC
Diamond Track Towing Trolley 30x30	1.20Kg

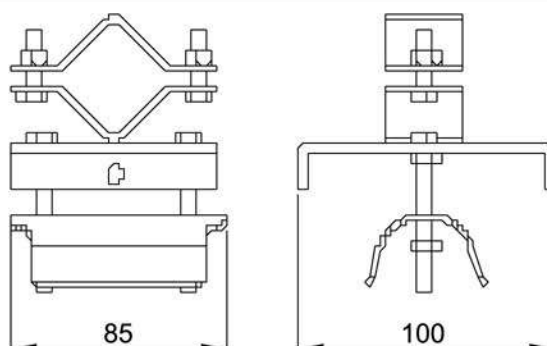

KY-OISP346	
方管末端固定夾 30x30	KG/PC
Diamond Track End Cable Clip 30x30	0.68Kg

九、安裝實績照 / Installation Performance Photos



• 賓利保養廠

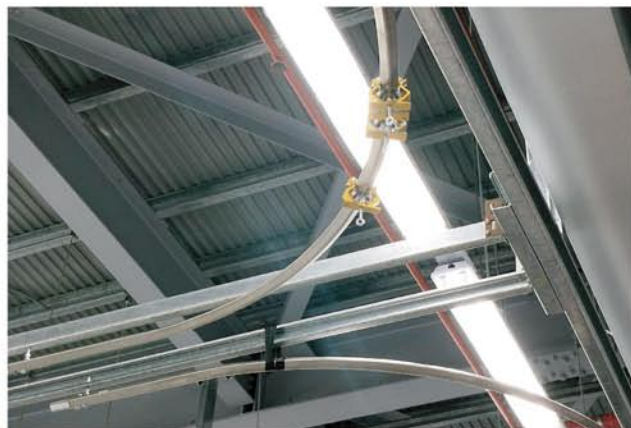

• 賓利保養廠：走彎式菱型軌道



• 各式機台移動供電



• 水平排線及垂直CBC電纜鍊條應用



• H滑車及扁電纜配電應用



• C型軌結合安全電軌應用



• C型軌配電應用



• C型軌配電應用 (無塵室)



• 重負荷電纜H滑車應用



• 戶外門型吊車以白鐵C軌系統供應縱行電力



• 雙C型軌分離式控制 (快拆火車頭)

本公司另備有關聯性產品及相關工程技術服務，歡迎來電洽詢工程技術部

●●●●● Welcome, contact with us about all parts or technical information, Thank's! ●●●●●

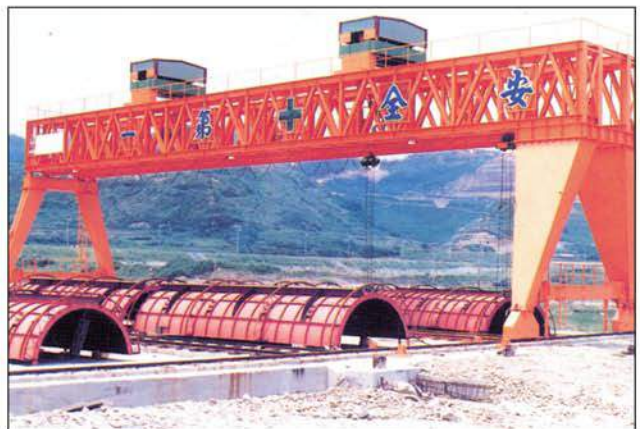
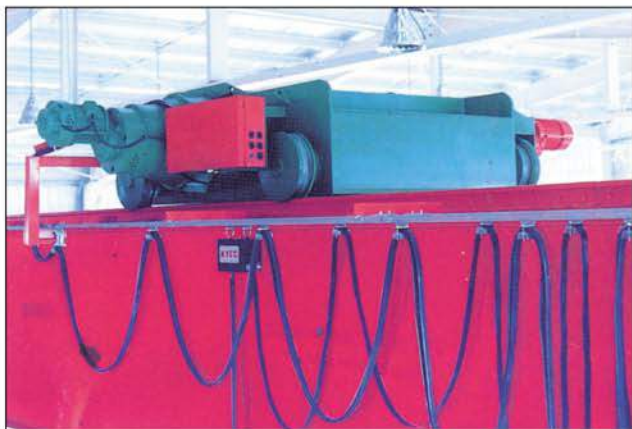
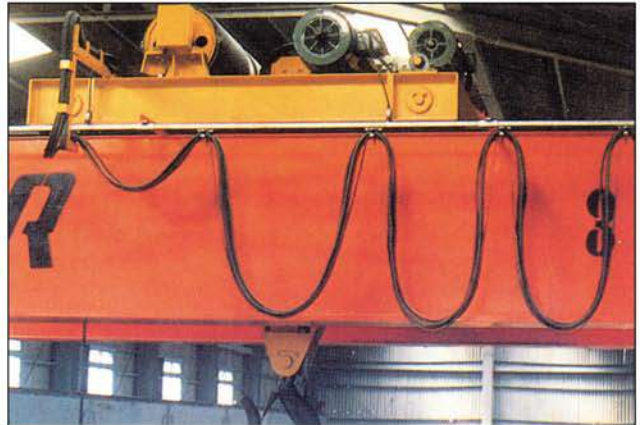

坤溢企業股份有限公司

Web: <http://www.kyec-mit.com.tw>

E-mail: taiwan.kyec@msa.hinet.net

總公司：333 桃園市龜山區頂湖二街65巷6號

TEL: (03) 3287888 FAX: (03) 3280770

台北服務處 / T: (02) 25948345 F: (02) 25968846

台中服務處 / T: (04) 23580075 F: (04) 23582646

高雄服務處 / T: (07) 732-3380 F: (07) 732-3360

